

# LINEATOR™ Advanced Universal Harmonic Filter



The LINEATOR Advanced Universal Harmonic Filter (AUHF) is a revolutionary advancement in the area of passive harmonic mitigation. No other device on the market can meet the stringent limits of IEEE Std 519 at an equivalent efficiency, size and cost.

When your application calls for a truly cost effective harmonic solution, the LINEATOR AUHF is the logical choice. It provides Engineers with a standard off-the-shelf solution for what used to be a very challenging engineering problem.

**As industry evolves, so does the Lineator. Mirus has expanded its product line to include two new Lineator models to meet your needs for those demanding applications.**

## Revolutionary Reactor Design

**Better than 18-Pulse performance from standard 6-Pulse Variable Speed Drives**

**Up to 3% more energy efficient than 18-Pulse or Active Front-end solutions and every bit as effective in treating harmonics**

**Will meet IEEE 519 Std for both current and voltage distortion**

**ABS Type Approved for marine applications**

**'Wide Spectrum Harmonic Filter' that treats all harmonics generated by 3-phase diode or thyristor bridge rectifiers**

## Lineator-HP™ High Performance model used where the highest power quality demands must be met

Once again MIRUS leads the way in innovative passive harmonic mitigation solutions with the introduction of its new LINEATOR-HP™ model which is designed to offer <5% THD(I). This level of harmonic mitigation matches Active Front end Drives (AFE'S) and Active Filter (AF) performance without the high frequency harmonics introduced by these more expensive and complex solutions. With the addition of a new reactor design that allows for onsite reactor impedance optimization, current distortion levels of <5% THD(I) are achieved without introducing excessive voltage drop or VSD instability.

## Lineator-ED™ Extreme Duty model used when the operating conditions and environments can be harsh

For extreme environments, such as excessive background voltage distortion (5% to 12% VTHD), high ambient (up to 55° C) or high elevation (above 3000 ft), Mirus now offers an extreme duty model for its Lineator AUHF. Our standard Lineator AUHF already outperforms any other competitive filter by guaranteeing performance when background voltage distortion is as high as 5%. In some applications however, such as marine vessels, drilling rigs and oil fields equipped with electrical submersible pumps (ESP's), existing voltage distortion levels will often exceed 5%. Also, when ambient temperature levels exceed 40° C or at higher elevations where the air is thinner, a more robust filter is required. The Lineator-ED model will meet this challenge.



## Design Considerations for Meeting Harmonic Limits in Variable Speed Drive Applications

### Features

- The most energy efficient harmonic solution for VSD's
- Meets harmonic limits for both land and marine VSD applications
- Guaranteed to meet IEEE Std 519 for both current and voltage distortion at the input terminals of the LINEATOR and PCC
- Wide Spectrum Harmonic Filter treats all major harmonics generated by VSD's and other 3-phase rectifier loads
- Total Demand Distortion (TDD) of the current at the LINEATOR input terminals will not exceed the limits as defined in Table 10.3 of IEEE Std 519
- Compatible with engine driven generators thanks to the extremely low capacitive reactance, even at no load
- Suppresses overvoltages caused by commutation notching, capacitor switching and other fast changing loads
- Suitable for application on multiple VSD's provided only VSD's are connected
- Models available for AC Drives and DC Drives or other controlled rectifiers

### Benefits

- Saves energy by reducing upstream harmonic losses while operating at >99% efficiency
- Will not resonate with other power system components or attract line side harmonics
- Frees up system capacity by restoring VSD to near unity power factor
- Removal of harmonics improves overall system power factor
- True Power factor > 0.95 from 30% to 100% load
- Low capacitive reactance ensures generator compatibility
- Low capacitive reactance also eliminates the need for capacitor switching contactors (contactors are available upon request)

The LINEATOR is a purely passive device consisting of a unique inductor combined with a relatively small capacitor bank. Its innovative design achieves reduction of all the major harmonic currents generated by VSD's and other similar 3-phase, 6-pulse rectifier loads. The resulting ITHD is reduced to <8% and is now available in a model that achieves <5%. Although referred to as a filter, the LINEATOR exhibits none of the problems that plague conventional filters.

### Harmonic Distortion Reduction

The filtering effectiveness of a trap filter is dependent upon the amount of harmonics present at untuned frequencies as well as the residual at the tuned frequency. To obtain performance better than 15% ITHD, multiple tuned branches are often required. Other broadband filters require relatively large capacitor banks (*2 to 3 times more than Lineator*) to achieve reasonable performance.

### Harmonics from other sources

As a parallel connected device, the conventional trap filter has no directional properties. It therefore, can easily be overloaded by attracting harmonics from upstream non-linear loads. The LINEATOR, on the other hand, will present a high impedance to line side harmonics eliminating the possibility of inadvertent importation and overloading.

### System Resonance

At frequencies below its tuned frequency, a conventional filter will appear capacitive. This capacitance has the potential of resonating with the power systems natural inductance. When a filter is tuned to a higher order harmonic, such as the 11th, it could easily resonate at a lower harmonic frequency, such as the 5th or 7th. Even the LCL passive filters required for low harmonic AFE Drives or parallel Active Harmonic Filters are susceptible to this problem. The natural resonance frequency of the LINEATOR is below that of any predominant harmonic, therefore inadvertent resonance is avoided.

### Capacitive Reactance and Leading Power Factor

The large capacitor banks in trap filters and competing broadband filters present a high capacitive reactance to the system, especially under light loads. On weak power systems, this can raise voltages or cause excitation control problems in generator applications. To address this, some filter manufacturers offer mechanisms for switching out the capacitors under light loads, increasing cost and complexity. This is not necessary for the LINEATOR because even under no load conditions, it's capacitive reactance (kVAR) remains below 15% of its kVA rating. This ensures compatibility with engine generators, without the need to switch out capacitors.

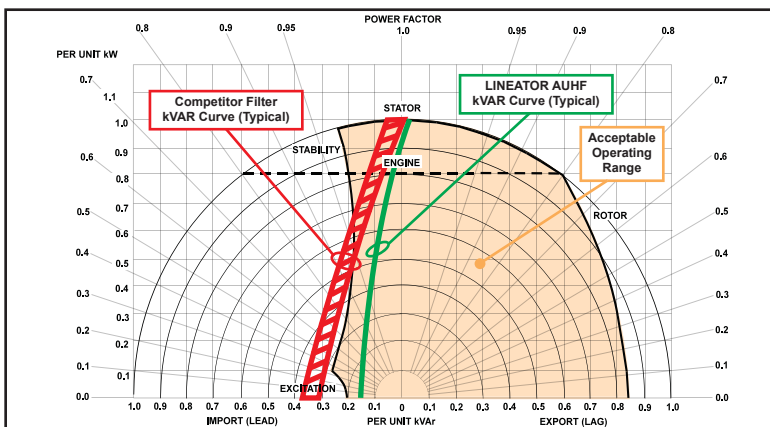

Generator Reactive Power Capability Curve

## Compare Performance!

The LINEATOR outperforms all other forms of VSD harmonic solutions. By choosing the LINEATOR you have selected a filter that:

- performs in Real World environments even with background voltage distortion and voltage imbalance
- lowers operating costs by being highly efficient
- is compatible with engine generators and incorporates a low capacitive reactance design
- has a simple and compact design to reduce footprint and ensure reliability
- can be computer modeled to provide up front assurance of meeting harmonic limit standards such as IEEE Std 519, ABS and other marine certifying bodies
- is factory performance tested under actual VSD loading

## Outperforms 18-P Solutions

As background voltage distortion increases, the harmonic mitigating performance of the 18-Pulse VSD degrades much quicker than the 6-Pulse / LINEATOR combination. This demonstrates that the LINEATOR AUHF will not attract harmonic currents as other non-linear loads distort the applied voltage waveform. LINEATOR is the only harmonic solution that guarantees performance even in heavily distorted environments.

There is little degradation in harmonic mitigating performance of the 6-Pulse / LINEATOR combination as voltage imbalance increases. The 18-Pulse solution, on the other hand, degrades dramatically because harmonic cancellation due to phase shifting becomes much less effective with 3-phase voltage imbalance.

The 6-Pulse VSD / LINEATOR combination has 2% to 3% higher efficiency than the 18-Pulse solution over the entire operating range. (Efficiency shown is for a system that includes motor/gen set load, VSD, and harmonic mitigation equipment). When compared to an 18-Pulse VSD, a 400HP AUHF/VSD will save more than \$3,000 in annual operating costs when averaging 75% loading at \$0.07/kWhr.

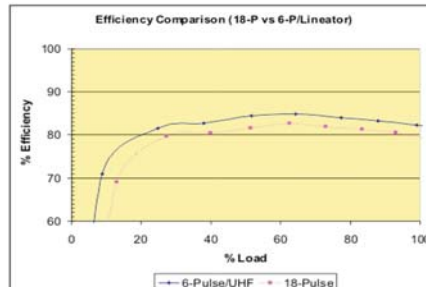
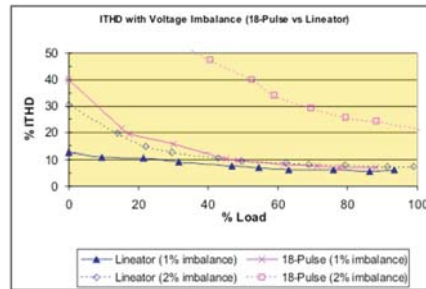
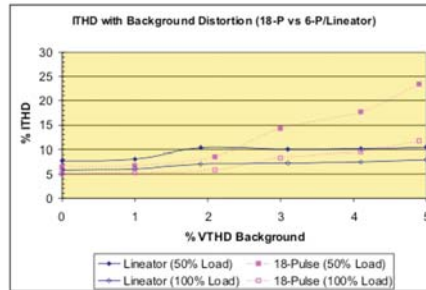

## Efficiency Comparison

The unique design of the AUHF produces extremely low losses. Its operating efficiency therefore is much higher than competitive filters. The graphs below show typical losses and efficiencies for AUHF and two competitors. (AUHF is available in sizes up to 3500HP. Since competitor maximum sizes are only 600HP and 900HP, the chart range has been set at 1000HP)

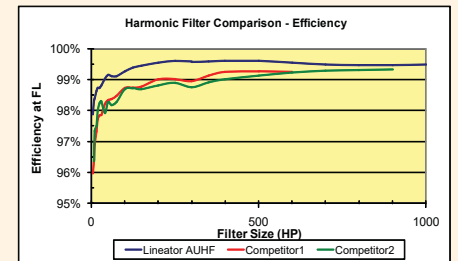
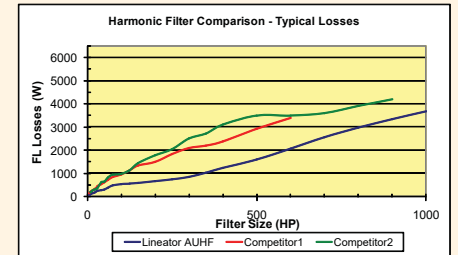

## Improves VSD Performance



VSD Input Current Waveform and Spectrum with no reactor.



VSD Input Current Waveform and Spectrum with AC reactor.

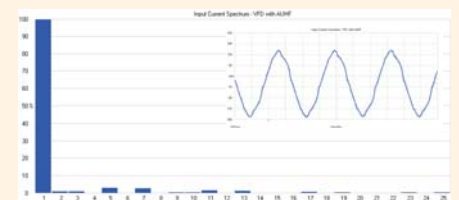

VSD Input Current Waveform and Spectrum with LINEATOR AUHF.

## 'Performance Guarantee'

MIRUS guarantees that the LINEATOR AUHF will perform as advertised to reduce harmonic distortion caused by AC Variable Speed Drives and other non-linear loads equipped with 3-phase, 6-pulse diode bridge rectifiers. A properly selected and installed LINEATOR will:

Reduce Current Total Harmonic Distortion (ITHD), measured at the LINEATOR input terminals at full load, to:

- (i) <8% when background voltage distortion is <5% and voltage imbalance is <3%
- (ii) <5% when short circuit ratio (Isc/IL), as defined by IEEE Std 519, is <20 and when background voltage distortion is <0.5% and voltage imbalance is <1%
- (iii) Reduce Current Total Demand Distortion (ITDD), measured at the LINEATOR input terminals over its entire operating range, to levels defined in Item (i) above. ITDD is defined as the ratio of ITHD divided by the full load current (peak demand current) of the LINEATOR.
- (iv) Minimize the contribution to Voltage Harmonic Distortion of all VSD's equipped with the LINEATOR to <5% total and <3% for individual harmonics, as defined by IEEE Std 519-1992.
- (v) NOT become overloaded by other upstream harmonic sources.
- (vi) NOT resonate with other power system components.
- (vii) NOT have compatibility problems with engine generator sets properly sized for the load.



## The Harmonics & Energy (H&E™) Lab

The Harmonics & Energy (H&E) Lab at MIRUS International Inc. provides the unique ability to test our products under 'real world' non-linear load conditions. We also conduct compatibility testing with all major VSD manufacturers' products to ensure a trouble-free installation.

Every LINEATOR is factory tested under VSD load to ensure our performance guarantee is met. No other manufacturer provides this level of testing whether they offer a passive filter, multi-pulse or active solution.



## SOLV™ Harmonic Analysis Software

MIRUS offers proprietary software called Simulation of LINEATOR / VFD (SOLV). SOLV is a powerful and unique computer simulation program that will calculate current and voltage distortion levels based on your load requirements.

By simply entering some basic information about your source and VSD system, you can generate very useful reports such as, an IEEE 519 Compliance Report. In addition to the accurate reports, you can print a single line representation of your system along with voltage and current waveforms and spectrums.

MIRUS' SOLV will help you find the right solution for your VSD application without the need of a costly harmonic study. It can be downloaded at [mirusinternational.com](http://mirusinternational.com)

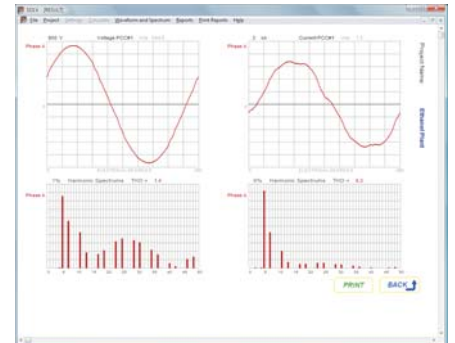
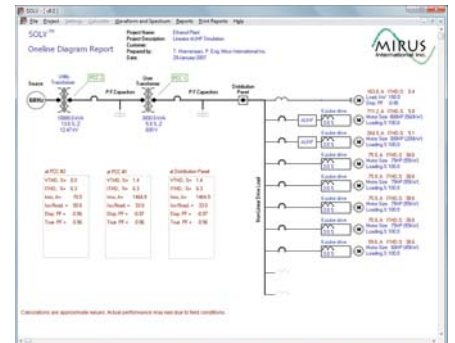

## Lineator Applications

### Oil & Gas Industry

Application of ASD's in the Oil and Gas Industry continues to grow at a rapid pace. This includes Electrical Submersible Pumps (ESP's), Top Drives and Mud Pumps on Drilling packages, Compressors, etc. Without harmonic mitigation, very serious consequences can result. Although not conclusively proven, high levels of harmonic distortion has been considered as a possible cause of off-shore drilling rig disasters in the Gulf of Mexico and the North Sea.

### Water & Waste Water

Although 18-Pulse ASD's are commonly used in the Water and Waste Water applications, there is a much better solution available. Lineator paired with a 6-Pulse ASD provides better harmonic mitigation performance especially if the supply has even low levels of voltage imbalance. And the Lineators much lower losses can result in thousands of dollars in energy savings annually.

### HVAC Systems

In many commercial buildings, the chillers, pumps and fan systems required for cooling represent a very large component of the building's electrical load. For today's Green Building designs, ASD's are being used on all of this equipment leading to harmonic distortion issues. To address this concern, Lineators are being used to eliminate harmonics without sacrificing any of the energy savings advantages of the ASD.

### Marine Vessels

Due to the serious consequences of high harmonic distortion, the American Bureau of Shipping (ABS), Det Norske Veritas (DnV) and all other Marine Certifying bodies have mandatory harmonic limits that must be met in order to attain certification. Since ASD's are now common-place on thrusters and main propulsion systems, these limits cannot be met without effective harmonic mitigation. The Lineator will meet these limits without introducing the troublesome high frequency harmonics associated with active solutions such as Active Front-end Drives and Active Harmonic Filters.

## Condition Based Maintenance Tool

When InSight™ is integrated into your system it provides essential health and performance information to the operator to let them know whether the equipment is operating within safe limits. For instance, should power quality or environmental conditions affect the normal operation of an Adjustable Speed Drive equipped with a Lineator Harmonic Filter and InSight™ monitor, operators can be notified of the filter's condition so that proactive action can be taken, if necessary.

Apply LINEATOR anywhere  
Variable Speed Drives and  
6-Pulse Rectifiers are used



- Oil and Gas industry
- Water and Waste Water
- Irrigation systems
- HVAC systems
- Mining operations
- Marine vessels
- Printing presses
- Elevators and escalators
- Pulp and paper processing
- Induction furnaces
- Industrial rectifiers
- Welding operations

Stay in touch with your  
equipment, locally or  
remotely



Mirus designed InSight™ as a web-based monitoring system allowing easy access via any web browser or by adding a touchscreen display at the equipment.









## **Expect better. Call us.**

To discuss how MIRUS can help you meet your power quality challenges, contact us at our head office:

MIRUS International Inc.  
31 Sun Pac Blvd.  
Brampton, Ontario  
Canada L6S 5P6

Tel: (905) 494-1120  
Fax: (905) 494-1140  
Toll-Free: 1-888-TO MIRUS (888-866-4787)

[www.mirusinternational.com](http://www.mirusinternational.com)

MIRUS Electromagnetic Equipment Co., Ltd.  
Suzhou, Jiangsu China

Tel : (86) 0512-62696858  
Fax : (86) 0512-62696266  
[www.cn.mirusinternational.com](http://www.cn.mirusinternational.com)



## **Harmonic and Energy Solutions**

**Real-world performance  
for real-world loads.**