



No.:

Date: 11-SEP-2020

Customer :

TECHNICAL PROPOSAL
Three-phase induction motor - Squirrel cage rotor

Product line : TEFC - Explosion Proof - NEMA Premium Efficiency

Catalog Number :

List Price : \$

Notes:

Performed by:

Checked:



No.:

Date: 11-SEP-2020

DATA SHEET

Three-phase induction motor - Squirrel cage rotor

Customer :
Product line : TEFC - Explosion Proof - NEMA Premium Efficiency

Frame : 324T
Output : 25 HP
Frequency : 60 Hz
Poles : 6
Full load speed : 1180 rpm
Slip : 1.67 %
Voltage : 208-230/460 V
Rated current : 67.2-61.6/30.8 A
Locked rotor current : 382/191 A
Locked rotor current (I_L/I_n) : 6.2
No-load current : 28.0/14.0 A
Full load torque : 110 lb.ft
Locked rotor torque : 210 %
Breakdown torque : 260 %
Design : B
Insulation class : F
Temperature rise : 80 K
Locked rotor time : 25 s (hot)
Service factor : 1.15
Duty cycle : S1
Ambient temperature : -20°C - +40°C
Altitude : 1000 m
Degree of Protection : IP55
Approximate weight : 639 lb
Moment of inertia : 10.808 sq.ft.lb
Noise level : 62 dB(A)

	D.E.	N.D.E.	Load	Power factor	Efficiency (%)
Bearings	6312 C3	6212 C3	100%	0.81	93.0
Regreasing interval	20000 h	20000 h	75%	0.77	93.0
Grease amount	21 g	13 g	50%	0.65	92.4

Notes:

Performed by

Checked



No.:

Date: 11-SEP-2020

PERFORMANCE CURVES RELATED TO RATED OUTPUT

Three-phase induction motor - Squirrel cage rotor

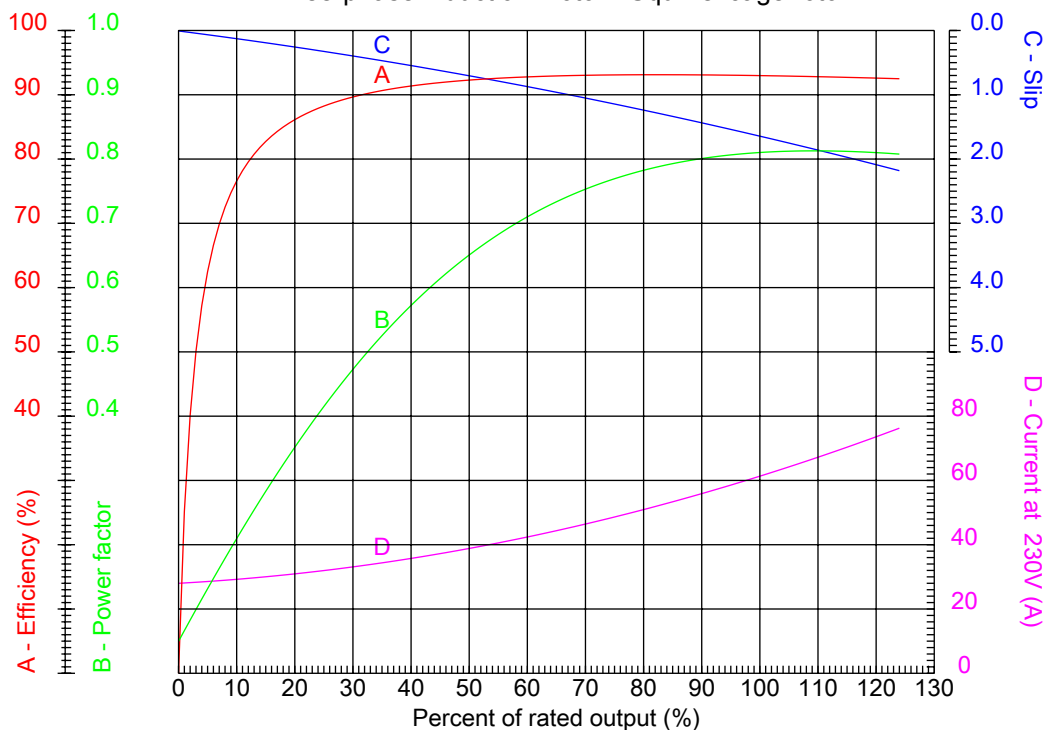

Customer :
Product line : TEFC - Explosion Proof - NEMA Premium Efficiency

Frame	: 324T	Locked rotor current (I _L /I _n)	: 6.2
Output	: 25 HP	Duty cycle	: S1
Frequency	: 60 Hz	Service factor	: 1.15
Full load speed	: 1180 rpm	Design	: B
Voltage	: 208-230/460 V	Locked rotor torque	: 210 %
Rated current	: 67.2-61.6/30.8 A	Breakdown torque	: 260 %
Insulation class	: F		

Notes:

Performed by

Checked



No.:

Date: 11-SEP-2020

CHARACTERISTIC CURVES RELATED TO SPEED

Three-phase induction motor - Squirrel cage rotor

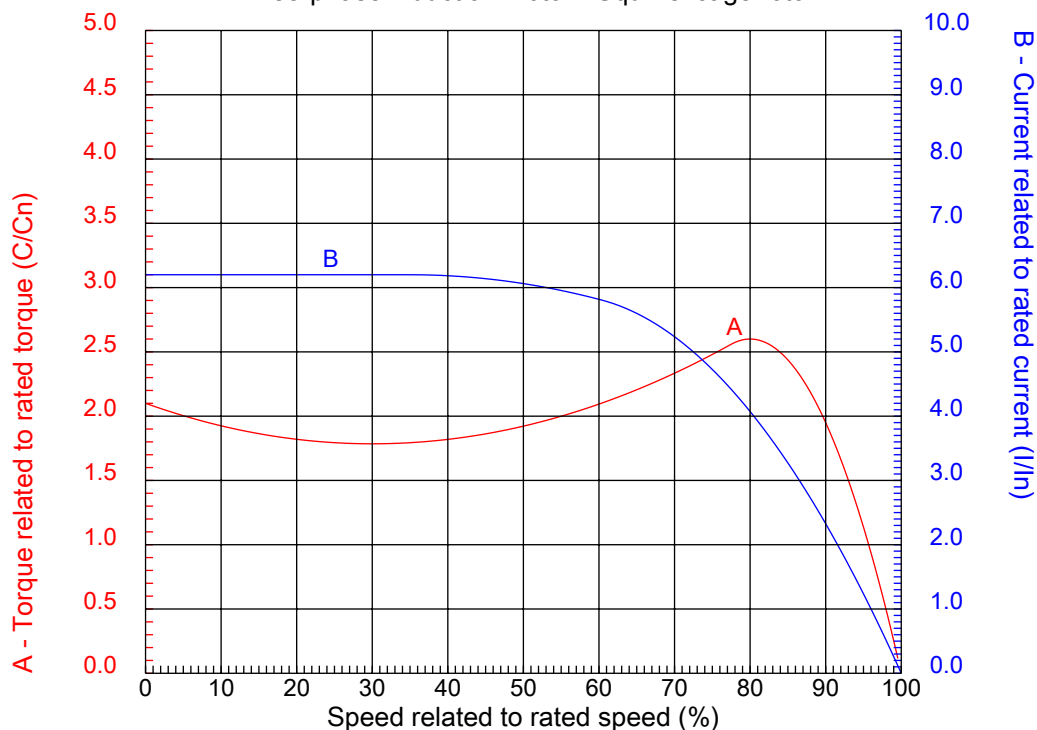

Customer :
Product line : TEFC - Explosion Proof - NEMA Premium Efficiency

Frame	: 324T	Locked rotor current (I _l /I _n)	: 6.2
Output	: 25 HP	Duty cycle	: S1
Frequency	: 60 Hz	Service factor	: 1.15
Full load speed	: 1180 rpm	Design	: B
Voltage	: 208-230/460 V	Locked rotor torque	: 210 %
Rated current	: 67.2-61.6/30.8 A	Breakdown torque	: 260 %
Insulation class	: F		

Notes:

Performed by

Checked

1 2 3 4 5 6 7 8

A

B

C

D

E

F

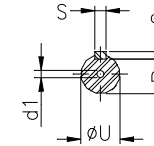
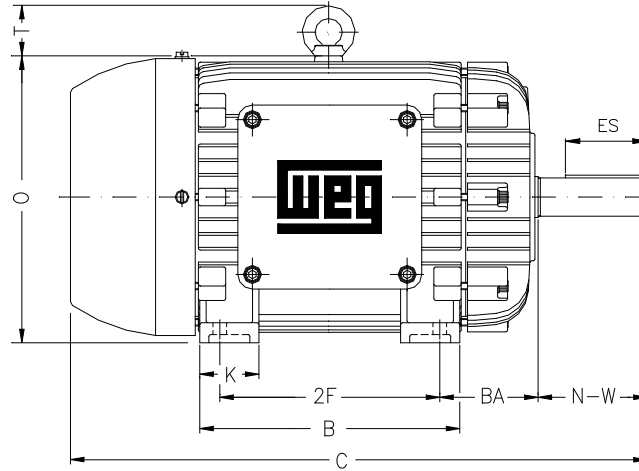

Notes:

Performed by:

Checked:

Customer:

TEFC - Explosion Proof - NEMA Premium Efficiency

Three-phase induction motor

Frame 324T - IP55

11-SEP-2020



2E 12.500	A 15.157	2F 10.500	B 13.071	BA 5.250
J 3.228	K 3.346	P 15.697	ES 3.937	depth 0.500
S 0.500	N-W 5.250	U 2.125	R 1.844	AB 12.953
D 8.000	G 1.307	O 15.992	T 2.795	H 0.657
C 29.606	AA NPT 2"	d1 A 4	d2 A 4	